

Ratings:
 Current 16A
 Voltage 250 V
 Wire Size 14-22AWG
 Test Voltage 1.5 kV
 Rated Torque / Screw Size 4kg-cm / M3

Dimensions:
 Spacing 7.5mm
 PCB Hole Diameter 1.3mm

Materials:
 Insulating Material PBT
 Flammability UL94V-0
 Temperature -33°C/+120°C
 Block CuZn
 Wire Guard Stainless Steel
 Screw Steel, Galvanized and Cromated

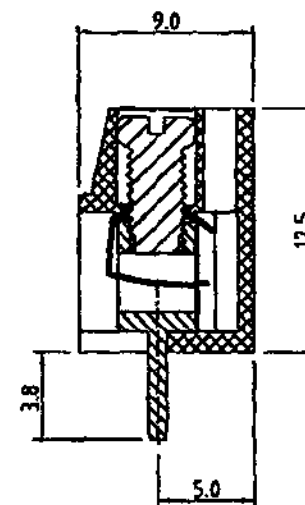
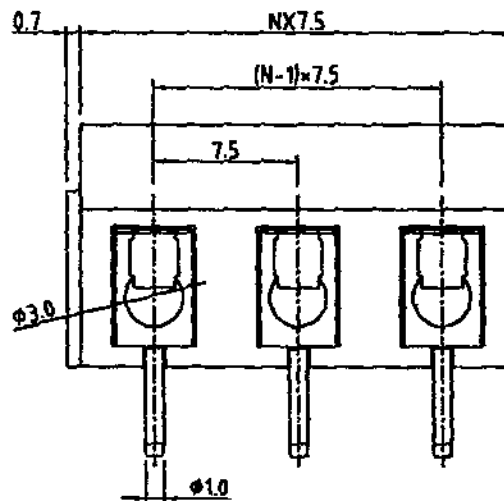
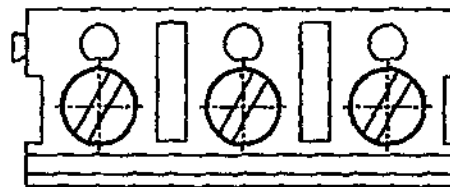

N=Number of contacts

P.C.B. LAYOUT

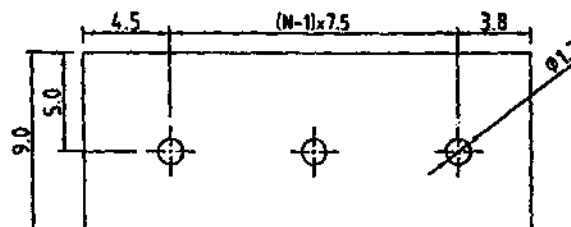

ON - SHORE TECHNOLOGY, INC.

Part Number
EDC110/[*][*]DS

* - NUMBER OF POSITIONS

Units
 mm

Drawing

Reviewed

Approved

Date
 2/12/00

Sheet 1 of 1

Rev. A